

Sleeve-Flex Elastomeric Couplings

Design Features

Need No Lubrication

No Maintenance

Quick & Easy Installation

Clean & quiet Performance

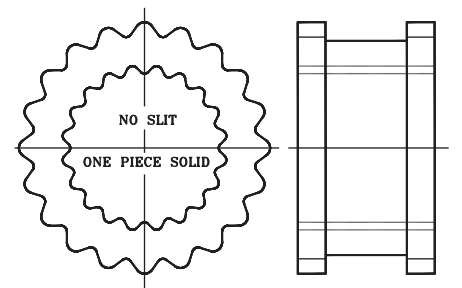

JE SLEEVES (FOR SIZE 3 TO 10)

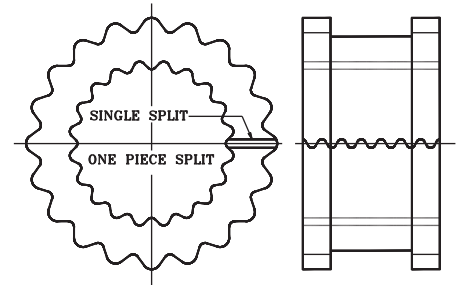

JES SLEEVES (FOR SIZE 3 TO 10).

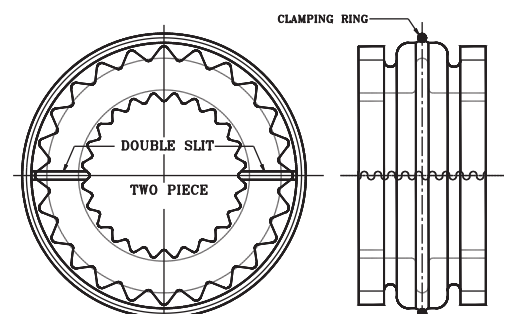

E SLEEVES (FOR SIZE 11 TO 13).

Sleeve-Flex can be installed quickly and easily, because there are no bolts, gaskets, covers or seals. Alignment can be checked with a straight edge placed across the outside of the precision machined flanges. No special tools are needed for installation, alignment or removal.

The teeth of sleeve lock into the teeth of the flanges without clamps or screws, tightening under torque to provide smooth transmission of power. There is no rubbing action of metal against rubber to cause wear. Couplings are not affected by abrasives, dirt or moisture.

This eliminates the need for lubrication or maintenance, provides clean, dependable, quiet performance.

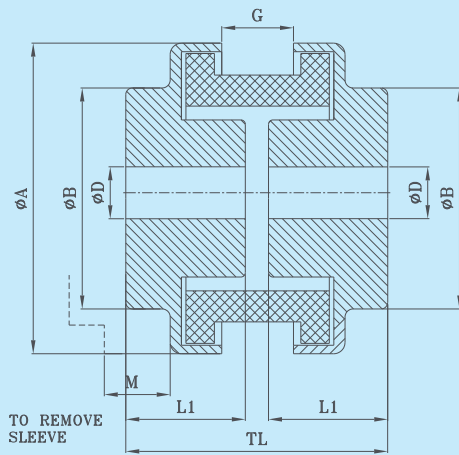

FLANGE
TYPE-'S'

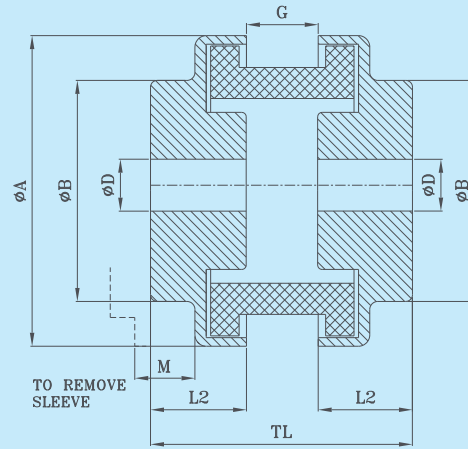

FLANGE
TYPE-'J'

TECHNICAL DATA

Coupling Size	Flange Type	Sleeve Type	kW @ 100 rpm	Rated Torque	Max. Speed	Bore (mm) ØD		Dimensions (mm)						Weight Kg	
				N-m	rpm	P.B.	MAX.	A	B	L1	L2	G	TL		M
3	J	JE, JES	0.08	7.64	9200	10	22	52	38	-	20	9	49	16	0.3
4	J		0.15	14.32	7600	13	25	63	41	-	22	16	60	16	0.5
5	J		0.30	28.65	7600	13	29	83	48	-	26	18	70	23	1.1
	S									34	-	19	71	30	
6	J		0.52	49.66	6000	16	35	102	63	-	33	21	87	28	2
	S									41	-	21	87	36	
7	S		0.90	85.94	5250	16	48	118	71	47	-	25	100	34	2.8
8	S		1.34	127.96	4500	19	54	138	98	53	-	28	112	38	4.8
9	S		2.16	206.26	3750	22	64	161	98	61	-	36	128	45	7.2
10	S		3.43	327.54	3600	29	73	191	111	69	-	41	144	51	11.2
11	S	E	5.37	512.80	3600	32	87	219	133	87	-	48	181	61	18
12	S		8.50	811.69	2800	38	98	254	146	102	-	60	211	68	28
13	S		13.43	1282.47	2400	51	100	299	171	111	-	68	236	78	48

- Flange Size 3 & 4 Are Available In Aluminium While 5 To 13 Are In Cast Iron.
- The Weight Is Approximate With Solid Flange.

- All dimensions are in mm unless otherwise specified.
- For vertical installation contact RATHI.

- In view of our constant endeavour to improve the quality of our products, we reserve the right to alter or change specifications without prior notice.
- This document is an intellectual property of Rathi Transpower Pvt. Ltd. and subject to copyright.



Rathi Transpower Pvt Ltd

Gaia Apex, S. No. 33/2D, Viman Nagar
 Pune 411 014, (INDIA)
 Phone : 91-20-30517201
 Fax : 91-20-30517212
 E-mail : enquiry@rathigroup.com
 Website : www.rathicouplings.com

Distributor